

TECHNICKÉ PARAMETRE TECHNICAL PARAMETERS

OHNIVO SKRUTKOVANÉ QUICK LINK

DODÁVATEĽ / SUPPLIER

ORVEX, spol. s r.o.
Klíňanská cesta 1225
029 01 Námestovo
Slovenská republika

Tel.: +421 43 5523371-3
Fax: +421 43 5522986
www.orvex.com

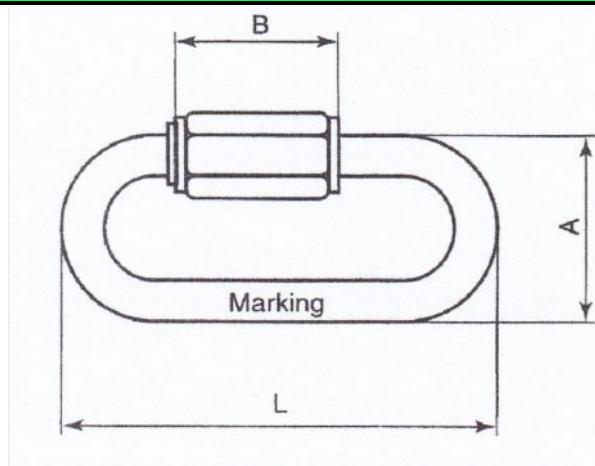
**KONTROLNÉ ČÍSLO
CONTROL NO.**
9/GM/2009

ROZMER/SIZE	L [mm]	A [mm]	B [mm]				Trhacie zaťaženie Breaking load [kg]	Pracovné zaťaženie Working load [kg]	Váha/ks Weight/ks [kg]
3,5 mm	37	17	12				300	100	0,0078
4 mm	41	19	13				540	180	0,0120
5 mm	48	23	16				840	280	0,0194
6 mm	57	26	19				1200	400	0,0346
7 mm	66	30	23				1650	550	0,0522
8 mm	73	33	24				2100	700	0,0706
10 mm	91	40	29				3330	1110	0,1430
12 mm	105	47	33				4500	1500	0,2050
14 mm	123	56	40				6660	2220	0,3514
16 mm	141	63	44				8700	2900	0,5168

MATERIÁL / MATERIAL
C15
KRYTIE / COVERING
zinok / galv.

Tolerancia rozmerov +/- 5 %
Dimension tolerance +/- 5 %

**TENTO DOKUMENT JE URČENÝ PRE INFORMATÍVNE ÚČELY.
ORIGINAL JE K DISPOZÍCII V SÍDLE SPOLOČNOSTI
ORVEX, SPOL. S R.O.**

THIS DOCUMENT IS FOR INFORMATIVE PURPOSES ONLY. THE
ORIGINAL IS AVAILABLE IN HEADQUARTER OF COMPANY ORVEX,
SPOL. S R.O.

DÁTUM / DATE

01.01.2010